



RD-S Series Mobile Mast

Summary ~ ITS RD-S Series ~ Multi-terrain Mobile Mast System

- A multi-terrain drawbar trailer with a 6,000lb (2,721kg) capacity GVWR ~ to 1,500lbs (680kg) of available deck top payload capacity; a single 6,000lb (2,721kg) capacity, heavy-duty Torflex axle, hydraulic/surge “free-backing” brakes with manual park brake telescopic outrigger stabilizing system, 12V/24V arctic/desert wiring and LED lighting package, adjustable height 2-5/16” ball coupler or NATO 3” (7.6cm) pintle; “D-ring” style integrated tie-down and lifting provisions, leveling devices, storage containment, tan painted or impact and weather resistant black polyuria trailer coating
- Standard mast elevations include $\pm 32'0''$ (9.7m), $\pm 44'0''$ (13.4m) and $\pm 62'0''$ (18.8m) AGL heavy-duty *locking telescopic pneumatic masts*, self-supporting and guy capable, rugged construction, high-strength heat treated aluminum tubes & collars, low-friction synthetic bearings, shock absorbing bumpers; includes mast base plate and external brackets; to 200lbs (91kg) mast payload capacity
- Heavy-duty, 120/220VAC/50-60Hz limit switch controlled electric tilt winch assembly, integrated safety features; trailer-level NEMA 4 locking enclosure houses mast operating controls – tilt and telescoping functions; onboard compressor system with convenient external power switch

The **RD-S Series** model designates a 6,000lb (2,721kg) capacity Gross Vehicle Weight Rating (GVWR), heavy-duty multi-terrain trailer and mast system designed to transport its integrated payload and support customer or ITS-installed equipment in a gross platform area comprising $\pm 10'0'' \times 7'1''$ (3m x 2.2m); net usable of ± 71 sq. ft. (6.6 sq. mtr). As designed, the trailer’s skeletal frame is engineered with a minimum factor of safety of 2:1, with 4:1 in critical load areas. A multi-section heavy-duty pneumatic locking mast is designed to transport horizontally over the trailer’s forward platform, automatically tilt by means of an HD electric cable winch assembly and extend to its full height utilizing an onboard compressor. The **RD-S Series** is capable of being deployed, elevated to full-height and secured by individual mast-section locks by one person in under 20 minutes.

ITS RD-S Series ~ Drawbar Trailer Specifications

- GVWR 6,000lb (2,721kg) Capacity; GAWR 6,000 (2,721kg) Capacity
- Single 6,000 (2,721kg) Dexter Torflex Axle, EZ Lube Grease
- Transport Length ~ $\pm 13'10''$ (4.25m); Transport Height $\pm 7'8''$ (2.38m)
- Trailer Length $\pm 13'3''/4m$ (3'3''/1m Drawbar); Width 2.16m; Deck $\pm 0.9m$
- Platform Area ~ Approx. 10' L x 7'1" W (3m x 2.1m); 57"/1.45m B/ Fenders
- Deployed Footprint~ $\pm 13'3''L$ (4m) x 14' (4.3m) W; 43" L (1m) Outriggers
- 1/8" (.33cm) Steel Plate Deck and Fenders; All Welded Construction
- Est. Weight w/out Client or ITS-Installed Accessories to $\pm 4,100$ lb (1,859kg)
- Customer Equipment Payload Capacity to 1,500 lbs (680kg)
- Four (4) HD Telescoping Outriggers; 7,000 lb (3,175kg) Static Load Jacks
- Hydraulic Brakes; 315/75R16 LR E 10-ply All-Terrain Tires
- Full Sized Spare with 16 x 8 hole Steel Wheels - Black
- Min. 3,175kg Static Load, Drop-leg, Adjustable Landing Gear
- Emergency Break-away Cable; LED Lighting Package
- Arctic/Desert Trailer Wiring; D-Ring Lift/Tie-Down Provisions
- 7.6cm Lunette (Pintle); 5/16" (.79cm) Chains w/Hook
- 7-Blade Truck Connector, Operating/Maintenance Manual
- Locking Storage Containment, Leveling Jack Transport Mounts
- Optional DOT Safety Decals; Reflectors; Multiple Trailer Levels
- Tan Painted or Black w/ Weather Resistant Polyuria Coating

Pneumatic Mast Selection ~ Will-Burt Models from 30'0" (9.1m) to 60'0" (18m)

The primary benefits and features of the Will-Burt pneumatic mast includes:

- » Locking collars allow the mast to remain extended indefinitely without air pressure
- » Rugged construction of high strength heat-treated aluminum tubes and collars with low friction synthetic bearings
- » Two full-length external keys on sections; collars have matching keyways that maintain directional azimuth
- » The bumpers are designed to reduce shock on extension and retraction
- » All exterior aluminum surfaces are anodized & sealed for long life; fasteners are plated steel for corrosion resistance
- » Payload capacity of the most appropriate models to 200lbs (91kg)
- » ITS secures the pneumatic mast within a heavy-duty lattice steel exoskeleton (“truss”) that protects the mast during the tilt function and offers added strength and stability to the extended mast structure
- » The truss-enclosed mast is secured to a square tube steel support structure that provides maximum protection and minimal deflection/vibration during primary and multi-terrain transport as well as during mast operation

REPRESENTATIVE RD-S SERIES MOBILE MAST

(Shown with Optional Features/Accessories)

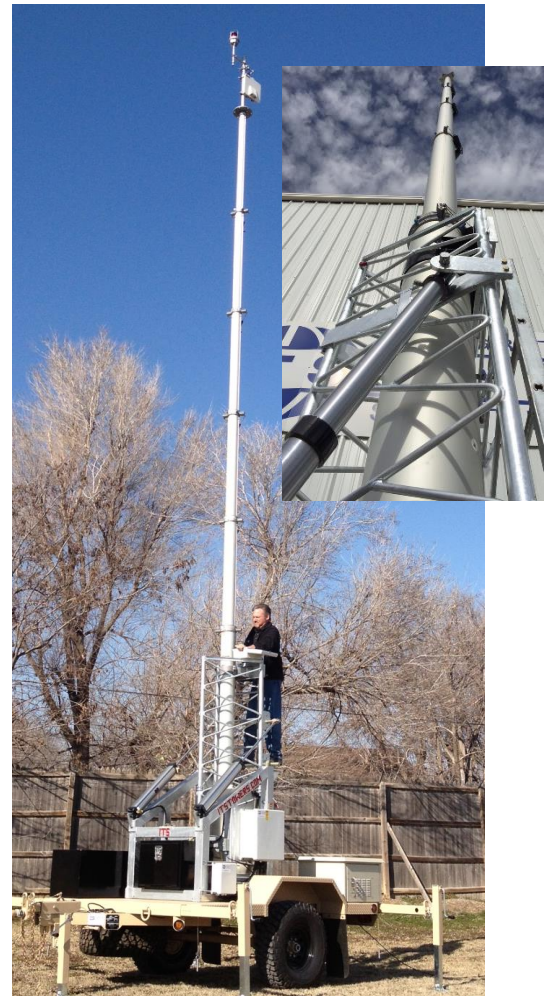

REPRESENTATIVE RD-S SERIES MOBILE MAST

(Electric Winch Tilt Assembly / 60' (18m) Mast)

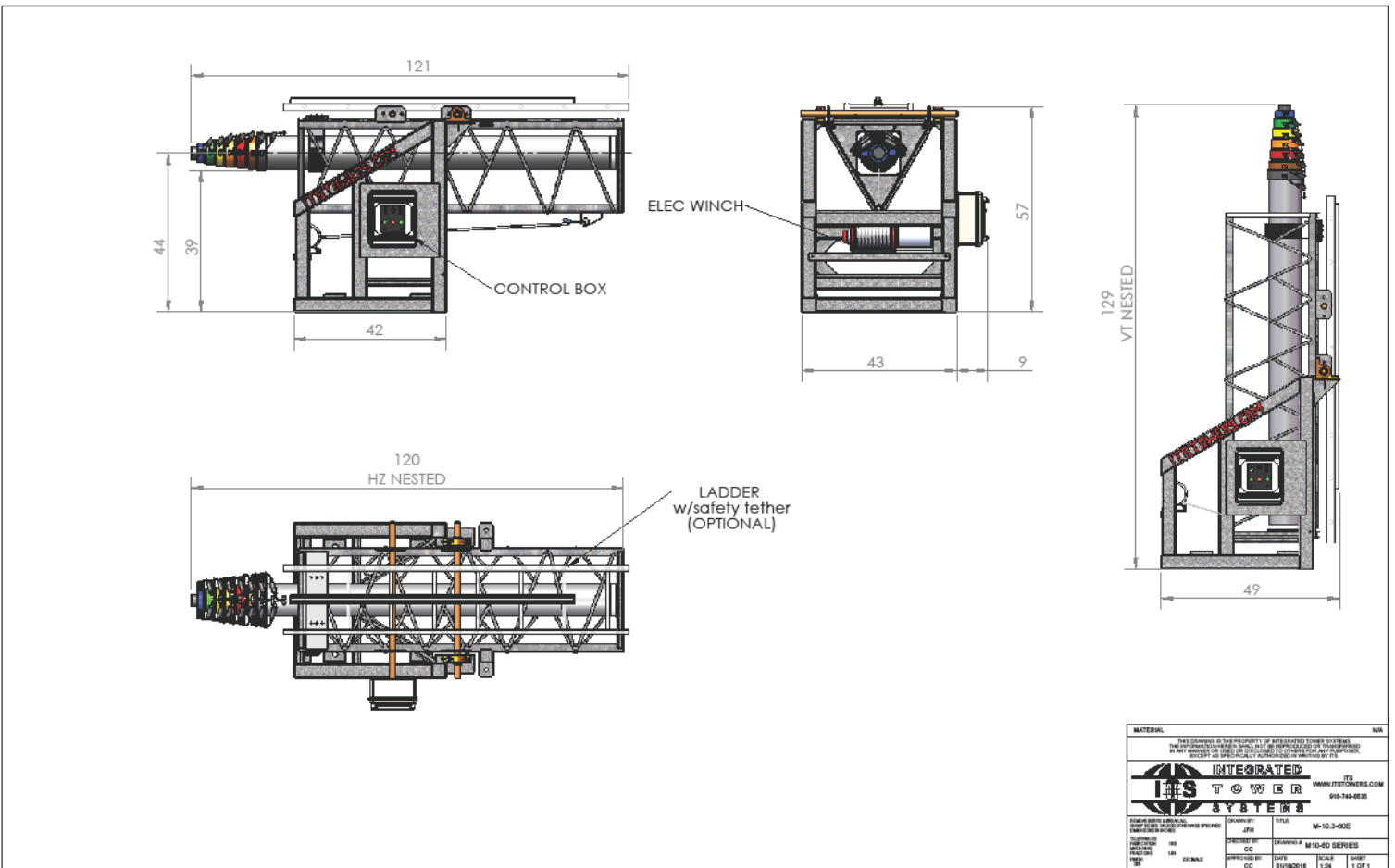
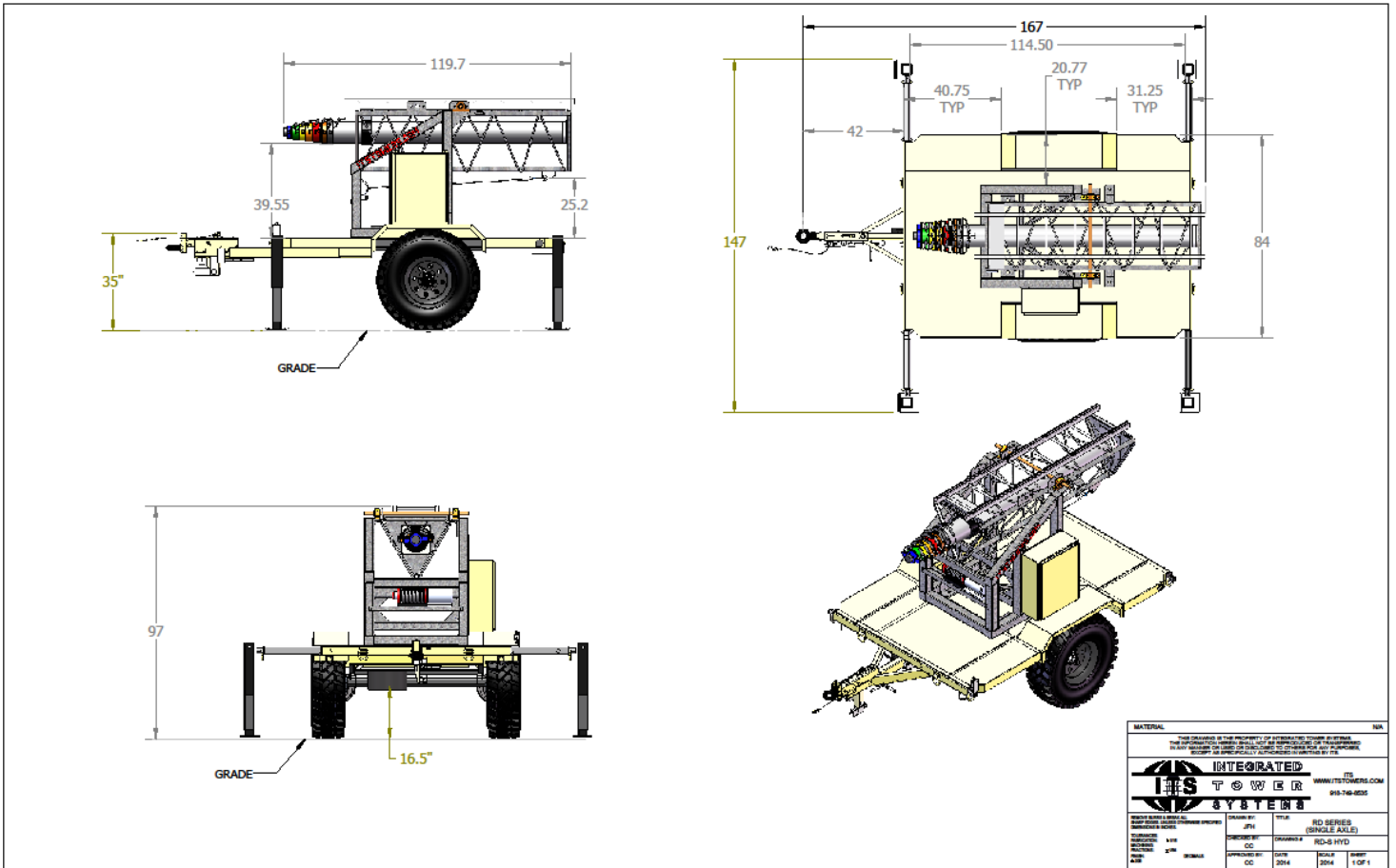

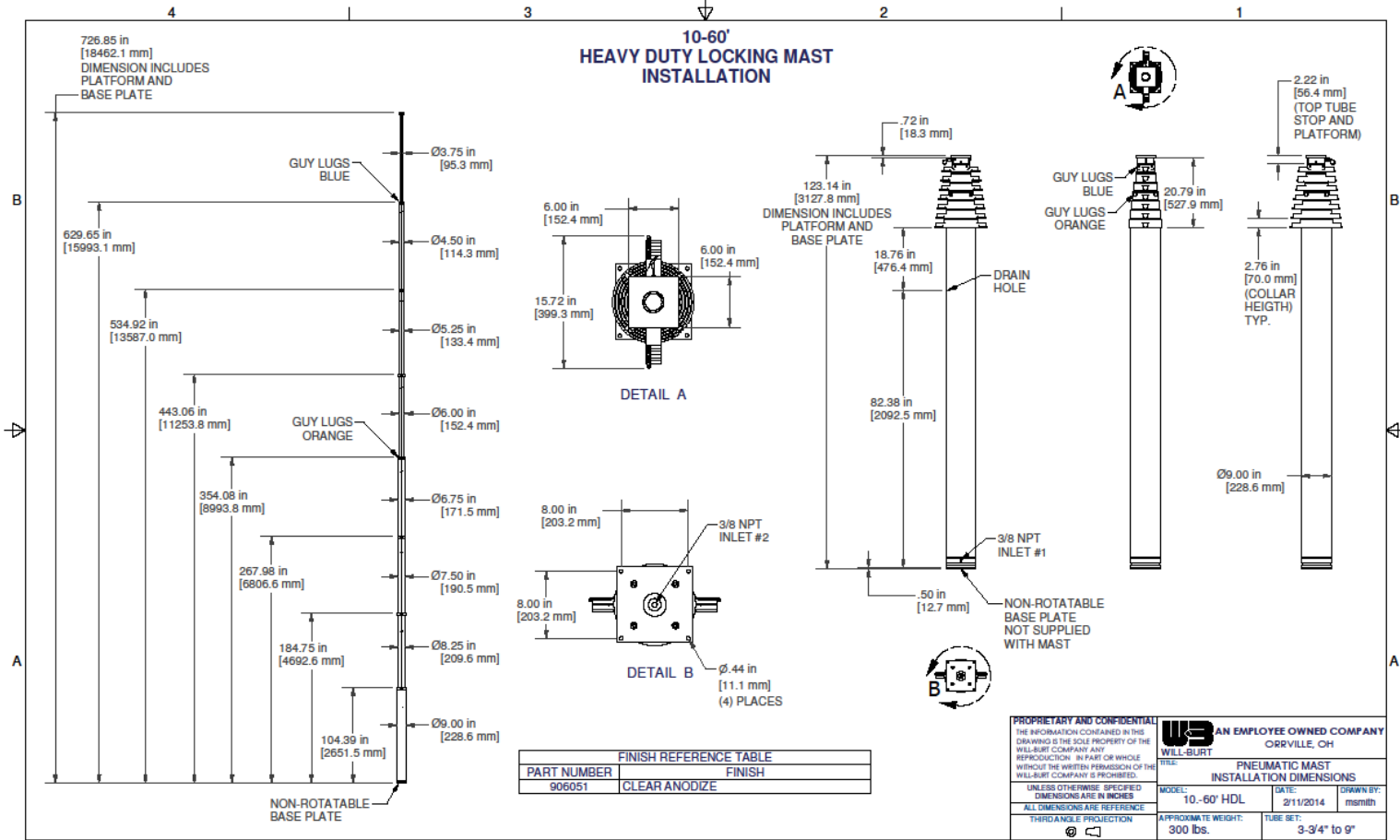

PROPRIETARY AND CONFIDENTIAL		WILL-BURT	
THE INFORMATION CONTAINED IN THIS DRAWING IS THE SOLE PROPERTY OF THE WILL-BURT COMPANY ANY REPRODUCTION IN PART OR WHOLE WITHOUT THE WRITTEN PERMISSION OF THE WILL-BURT COMPANY IS PROHIBITED.		AN EMPLOYEE OWNED COMPANY ORRVILLE, OH	
TITLE	PNEUMATIC MAST INSTALLATION DIMENSIONS	MODEL	10-60' HDL
DATE	2/11/2014	APPROXIMATE WEIGHT	300 lbs.
DRAWN BY	msmith	TUBE SET	3-3/4" to 9"

